

# ATG Stirnradgetriebemotor Reihe KST modular

ATG helical gears  
Series KST modular

## Preise Pricelist

2025 / 2026 Listenpreise / list prices

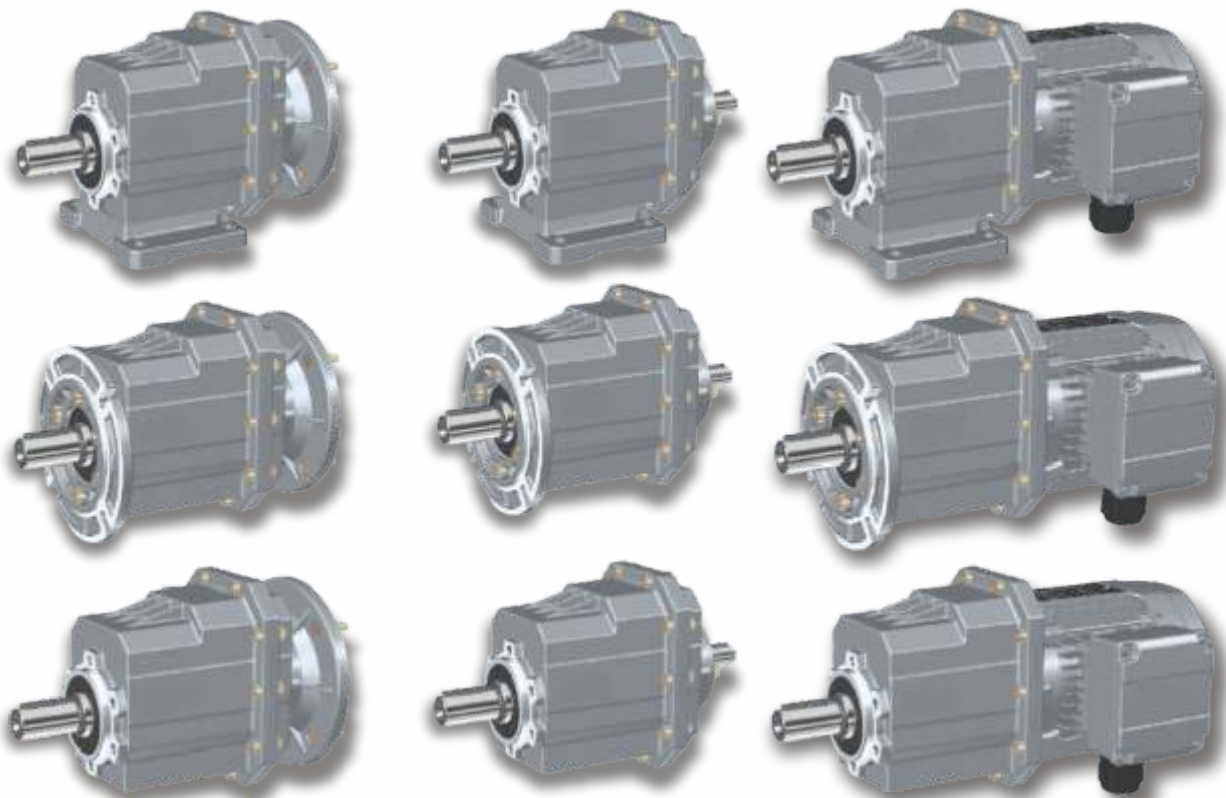

Preisliste Stirnradgetriebe Serie KST modular  
Pricelist helical gear series KST modular

KST...P/TAM(IEC)



KSTF...P/TAM(IEC)



KSTZ...P/TAM(IEC)



Getriebe Gear	Motor Flansch Motor flange				Eingang Hohlwelle D/ Input shaft hole diameter D																Listenpreis* list price*
	IEC	P	M	N	Übersetzung / Transmission ratio																
					53.33	45.89	40.10	35.47	28.50	23.56	19.83	17.86	14.62	13.80	11.90	9.81	9.17	7.72	5.69	4.63	
KSTo1	63B5	140	115	95	11	11	11	11	11	11	11	11	11	11	11	11	11	11	11		
	71B5	160	130	110	14	14	14	14	14	14	14	14	14	14	14	14	14	14	14		
KSTFo1	71B14	105	85	70	14	14	14	14	14	14	14	14	14	14	14	14	14	14	14		
	80B5	200	165	130	19	19	19	19	19	19	19	19	19	19	19	19	19	19	19		
KSTZo1	80B14	120	100	80	19	19	19	19	19	19	19	19	19	19	19	19	19	19	19		
	90B5	200	165	130	24	24	24	24	24	24	24	24	24	24	24	24	24	24	24		
Welle/ Shaft d= 20mm	90B14	140	115	95	24	24	24	24	24	24	24	24	24	24	24	24	24	24	24		

665,00 €

Getriebe Gear	Motor Flansch Motor flange				Eingang Hohlwelle D/ Input shaft hole diameter D																Listenpreis* list price*
	IEC	P	M	N	Übersetzung / Transmission ratio																
					54.00	46.46	40.60	35.91	28.88	23.85	20.08	17.10	14.81	13.21	12.05	9.93	8.78	7.39	5.45	4.43	
KSTo2	63B5	140	115	95	11	11	11	11													
	71B5	160	130	110	14	14	14	14	14	14	14	14	14								
KSTFo2	71B14	105	85	70	14	14	14	14	14	14	14	14	14								
	80B5	200	165	130	19	19	19	19	19	19	19	19	19	19	19	19	19	19	19		
KSTZo2	80B14	120	100	80	19	19	19	19	19	19	19	19	19	19	19	19	19	19	19		
	90B5	200	165	130	24	24	24	24	24	24	24	24	24	24	24	24	24	24	24		
Welle/ Shaft d= 25mm	90B14	140	115	95	24	24	24	24	24	24	24	24	24	24	24	24	24	24	24		

712,50 €

Getriebe Gear	Motor Flansch Motor flange				Eingang Hohlwelle D/ Input shaft hole diameter D																Listenpreis* list price*
	IEC	P	M	N	Übersetzung / Transmission ratio																
					58.09	50.02	43.75	38.73	34.62	28.30	21.78	17.33	15.06	12.37	10.28	7.93	6.31	5.48	4.50	3.74	
KSTo3	71B5	160	130	110	14	14	14	14	14												
	71B14	105	85	70	14	14	14	14	14												
KSTFo3	80B5	200	165	130	19	19	19	19	19	19	19	19	19	19							
	80B14	120	100	80	19	19	19	19	19	19	19	19	19	19							
KSTZo3	90B5	200	165	130	24	24	24	24	24	24	24	24	24	24	24	24	24	24	24		
	90B14	140	115	95	24	24	24	24	24	24	24	24	24	24	24	24	24	24	24		
Welle/ Shaft d= 30mm	100B5	250	215	180					28	28	28	28	28	28	28	28	28	28	28		
	100B14	160	130	110					28	28	28	28	28	28	28	28	28	28	28		
	112B5	250	215	180					28	28	28	28	28	28	28	28	28	28	28		
	112B14	160	130	110					28	28	28	28	28	28	28	28	28	28	28		

762,50 €

Getriebe Gear	Motor Flansch Motor flange				Eingang Hohlwelle D/ Input shaft hole diameter D																Listenpreis* list price*
	IEC	P	M	N	Übersetzung / Transmission ratio																
					58.09	50.02	43.75	38.73	34.62	28.30	21.78	17.33	15.06	12.37	10.28	7.93	6.31	5.48	4.50	3.74	
KSTo4	80B5	200	165	130	19	19	19	19	19	19											
	80B14	120	100	80	19	19	19	19	19	19											
KSTFo4	90B5	200	165	130	24	24	24	24	24	24	24	24	24	24	24	24	24	24	24		
	90B14	140	115	95	24	24	24	24	24	24	24	24	24	24	24	24	24	24	24		
Welle/ Shaft d= 35mm	100/112B5	250	215	180					28	28	28	28	28	28	28	28	28	28	28		
	100/112B14	160	130	110					28	28	28	28	28	28	28	28	28	28	28		

775,00 €

Getriebe Gear	Motor Flansch Motor flange				Eingang Hohlwelle D/ Input shaft hole diameter D																Listenpreis* list price*
	IEC	P	M	N	Übersetzung~ / Transmission ratio~																
					56.08	48.29	42.23	37.38	33.42	30.12	24.92	21.03	16.72	12.73	11.57	10.02	8.72	7.62	6.31	5.47	
KSTo5	90B5	200	165	130	24	24	24	24	24	24	24	24	24	24	24	24	24	24	24		
	100B5	250	215	180	28	28	28	28	28	28	28	28	28	28	28	28	28	28	28		
KSTFo5	112B5	250	215	180	28	28	28	28	28	28	28	28	28	28	28	28	28	28	28		
	132S/MB5	300	265	230	38	38	38	38	38	38	38	38	38	38	38	38	38	38	38		
KSTZo5	132MLB5	300	265	230	38	38	38	38	38	38	38	38	38	38	38	38	38	38	38		
	160B5	350	300	250	42	42	42	42	42	42	42	42	42	42	42	42	42	42	42		

auf Nachfrage  
on request

Getriebe Gear	Motor Flansch Motor flange				Eingang Hohlwelle D/ Input shaft hole diameter D																Listenpreis* list price*
	IEC	P	M	N	Übersetzung~ / Transmission ratio~																
					58.78	51.56	45.79	41.06	37.13	30.94	26.30	21.17	16.68	15.03	13.18	11.63	10.31	8.81	8.04	7.06	
KSTo6	90B5	200	165	130	24	24	24	24	24	24	24	24	24	24	24	24	24	24	24		
	100B5	250	215	180	28	28	28	28	28	28	28	28	28	28	28	28	28	28	28		
KSTFo6	112B5	250	215	180	28	28	28	28	28	28	28	28	28	28	28	28	28	28	28		
	132S/MB5	300	265	230	38	38	38	38	38	38	38	38	38	38	38	38	38	38	38		
KSTZo6	132MLB5	300	265	230	38	38	38	38	38	38	38	38	38	38	38	38	38	38	38		
	160B5	350	300	250	42	42	42	42	42	42	42	42	42	42	42	42	42	42	42		

auf Nachfrage  
on request

\*+10% für Anbau an IEC Motor / +10% for mounting on IEC motor

Ausgangsflansch/ Output flange

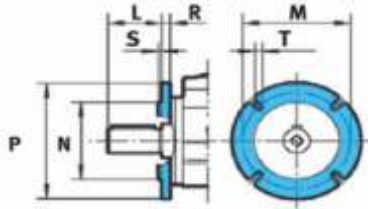

		size	P	M	N	T	L	R	S	Listenpreis list price
KSTF01	I	120	100	80	7	40	8	3		40,00 €
	II	140	115	95	9	40	9	3		47,50 €
	III	160	130	110	9	40	10	3.5		57,50 €
KSTF02	I	140	115	95	9	50	9	3		50,00 €
	II	160	130	110	9	50	10	3.5		60,00 €
	III	200	165	130	11	50	11	3.5		65,00 €
KSTF03	I	160	130	110	9	60	10	3.5		60,00 €
	II	200	165	130	11	60	11	3.5		87,50 €
	III	250	215	180	13	60	13	4		137,50 €
KSTF04	I	160	130	110	11	70	11	3.5		65,00 €
	II	200	165	130	12	70	12	3.5		92,50 €
	III	250	215	180	14	70	14	4		142,50 €
KSTF05	I	250	215	180	13.5	80	13	4		147,50 €
	II	300	265	230	13.5	80	13	4		197,50 €
KSTF06	I	300	265	230	13.5	100	16	4		202,50 €
	II	350	300	250	17.5	100	18	5		252,50 €

Fuß code/ Foot code

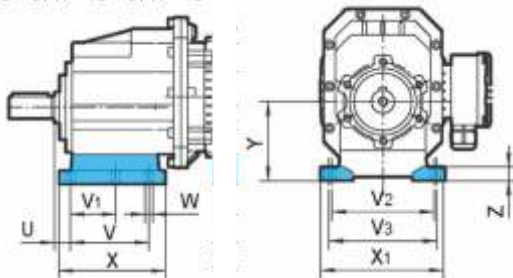

		size	U	V	V1	V2	V3	W	X	X1	Y	Z	Listenpreis list price
KST01	Bo1	18	87	50	110	-	9	118	130	90	15		62,50 €
	Mo1	18	80	-	110	120	9	118	145	80	15		62,50 €
KST02	Bo2	18	107.5	60	130	-	11	136	155	100	17		62,50 €
	Mo2	25	85	-	110	120	9	112	145	80	15		82,50 €
KST03	Bo3	18	130	70	160	-	11	156	190	110	20		117,50 €
	Mo3	30	100	-	135	150	11	150	190	110	18		112,50 €
	Bo4	20.5	130	-	170	-	14	168	205	105	20		125,00 €
	Mo4	32	110	-	170	185	14	150	230	110	20		127,50 €
KST04	Bo3	21	130	70	160	-	11	156	190	120	20		117,50 €
	Mo3	33	100	-	135	150	11	150	190	120	18		112,50 €
	Bo4	23.5	130	-	170	-	14	168	205	115	20		125,00 €
	Mo4	35	110	-	170	185	14	150	230	120	20		127,50 €
KST05	Bo5	19.5	149.5	-	180	-	14	185	215	130	20		142,50 €
	Bo501	25	156	-	225	-	18	200	270	155	22		162,50 €
KST06	Bo502	35	205	-	170	-	17.5	245	220	140	20		237,50 €
	Bo601	25	180	-	250	-	18	232	300	195	25		200,00 €
KST06	Ro602	40	260	-	215	-	17.5	310	280	180	25		287,50 €

IEC Eingangsflansch/ IEC input flange

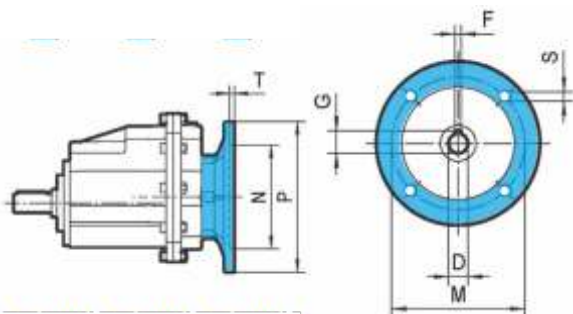

		IEC	D	F	G	P	M	N	S	T	Listenpreis list price
KST01	KST02	P63B5	11	4	12.8	140	115	95	9	4	57,50 €
		P71B5	14	5	16.3	160	130	110	9	4	57,50 €
		P71B14	14	5	16.3	105	85	70	7	4	55,00 €
		P80B5	19	6	21.8	200	165	130	11	4	57,50 €
		P80B14	19	6	21.8	120	100	80	7	4	57,50 €
		P90B5	24	8	27.3	200	165	130	11	4	77,50 €
KST03	KST04	P90B14	24	8	27.3	140	115	95	9	4	57,50 €
		P71B5	14	5	16.3	160	130	110	9	4	67,50 €
		P80B5	19	6	21.8	200	165	130	11	4	77,50 €
		P80B14	19	6	21.8	120	100	80	7	4	62,50 €
		P90B5	24	8	27.3	200	165	130	11	4	77,50 €
		P90B14	24	8	27.3	140	115	95	9	4	62,50 €
KST05	KST06	P100/112B5	28	8	31.3	250	215	180	13.5	4.5	122,50 €
		TAM90B5	24	8	27.3	200	165	130	11	4.5	92,50 €
		TAM100/112	28	8	31.3	250	215	180	13.5	5	137,50 €
		TAM132B5	38	10	41.3	300	265	230	13.5	5	172,50 €
KST06	KST06	TAM160B5	42	12	45.3	350	300	250	17.5	6	222,50 €

**Werner Krauter GmbH**  
Siemensstraße 2  
D-73037 Göppingen  
Telefon 07161 / 9383-0  
E-Mail [info@krauter.de](mailto:info@krauter.de)

[www.krauter.de](http://www.krauter.de)

